

SF2-B30 M4



SF2-B30 M5



SF2-B30 M6



SF2-B30 M8

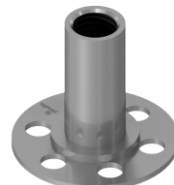

SF2-B30 M10



Description

bigHead fastener with an internally threaded collar fixing welded to a blind \varnothing 30 mm circular perforated Head. Suitable for surface bonding applications requiring a standoff with defined height.

Key features



Blind Head

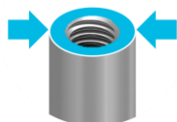

Collar diameter to suit ISO 273 clearance holes



Perforated head design



Shouldered collar geometry



316 stainless steel construction, self colour finish

Intended usage

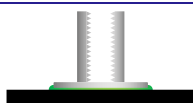

Alternative configurations may be possible using this product.



Please contact bigHead for further advice.

Surface bonding, standoff

Fastening functionality

Provides an internally threaded connection point for assembling threaded screws and similar secondary fasteners into.

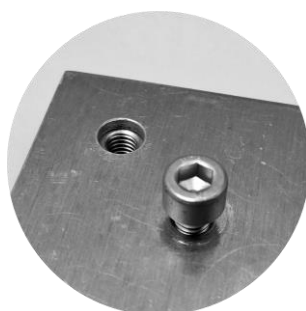

Torque tightening & preload during assembly: these products require specific consideration, please see torque & preload guidance section.

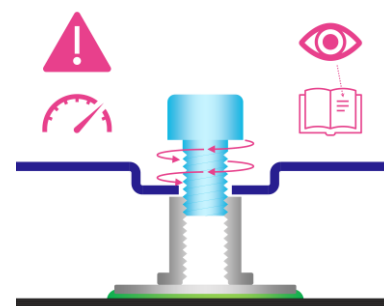

Nominal dimensions (mm)

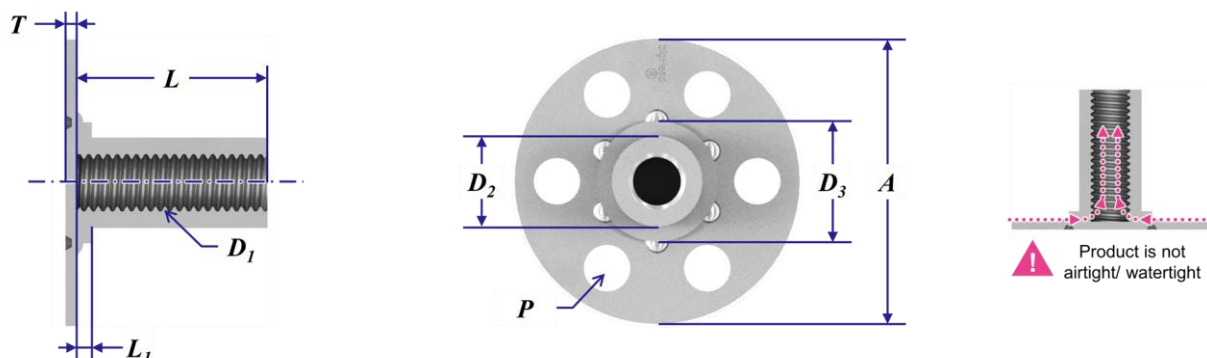

Product code	D1	D2 (Ø)	D3 (Ø)	A (Ø)	L	L1	T	Typical min. weight (g)
SF2 B30 M4	M4 x 0.70	6.3	10.0	30	Nominal thread length value	1.6	1.2	8
SF2 B30 M5	M5 x 0.80	9.5	12.7	30		1.6	1.2	10
SF2 B30 M6	M6 x 1.00	9.5	12.7	30		1.6	1.2	10
SF2 B30 M8	M8 x 1.25	11.0	16.0	30		1.6	1.2	12
SF2 B30 M10	M10 x 1.50	12.7	16.0	30		1.6	1.2	11

Common to all:

Thread class: 6H post finish

P - 6 perforation holes, equally spaced circular array

Design & application guidance

Thread size	Tightening torque			Loadability (Fixing)	Loadability (Weld)	Clearance holes
	Max. tightening torque (Nm)			Max. tensile load (kN)	Max. tensile load (kN)	Max. recommended hole size (mm)
	Friction coefficient:					
	0.1	0.2	0.3			
M4	0.9	1.4	1.7	8.2	5.6	4.5
M5	1.6	2.6	3.3	13.7	6.1	5.5
M6	2.9	4.6	5.7	16.0	6.5	6.6
M8	7.1	11.2	13.9	21.0	5.5	9.0
M10	14.0	22.2	27.6	21.7	Contact bigHead	11.0

Based on VDI 2230, 90% utilisation of yield strength. Valid only for intended usage configuration.

Applicability depends on the assembly system friction coefficient, which may vary according to the secondary fastener(s) specification.

For guidance only, determination of correct assembly parameters may require specialist expertise.

Always conduct suitable torque/preload calculation and appropriate validation for the intended assembly design.

Fixing load limit (FLL):

To avoid failure of the bigHead fastener, do not exceed stated loadability limits during in-service mechanical loading or assembly preloading.

Weld load limit (WLL):

bigHead is not liable for failures arising from excessive tensile loading or assembly preloading of their products.

ISO 273 "medium" clearance hole basis.

Please contact bigHead for further guidance if you are unsure about these topics.

Disclaimer

The information within this document is for guidance purposes only and does not constitute a guarantee or warranty of any kind.

bigHead cannot accept liability for performance arising from use of these products.

Always perform appropriate testing and evaluation to determine application suitability.

Illustrations and diagrams are for illustrative purposes only and may differ from actual products.

Further information & contact details

For further information about these products, or for technical support inquiries, please contact us:

www.bighead.co.uk/the-techub/

Tech@bighead.co.uk

+44 (0)1202 583 696

bigHead Bonding Fasteners Ltd

Unit 1, Black Moor Business Park

36A Black Moor Road

Ebblake Industrial Estate

Verwood

Dorset

United Kingdom

BH31 6BB